



THREE-DIMENSIONAL FINITE ELEMENT MODELLING OF CURRENT DENSITY IN MATERNAL TRANSTHORACIC DEFIBRILLATION

A. Jeremić, J. Potts and E. Khosrowshahli

Department of Electrical and Computer Engineering, McMaster University, Hamilton, Canada

Introduction

Cardiac arrest during pregnancy can have significant impact in terms of age of mother, mortality of unborn children (especially with potential loss of two lives) and consequently long-term effect on a family.

With recent advances in understanding pathophysiologies behind electrical shock in pregnant women it became more obvious that previous studies of current conduction in human body should be extended to account adequately for changes in maternal body that affect conduction pathways.

It has been shown that physiological changes in pregnancy affect transthoracic impedance and thus affect transmucardial current which depolarizes heart (myocardium) as a part of resuscitation. However due to the physiological changes (e.g. size of uterus, increased intra- and extracellular fluid, increased blood volume, increased thoracic volume, and presence of amniotic liquid) the transthoracic impedance changes may affect current pathways in an unpredictable way.

In this paper we present a three-dimensional simplified model for finite-element analysis of maternal transthoracic defibrillation. In this procedure an electrical pulse is applied to the torso through electrodes commonly called paddles.

One of the most important aspects is the energy or current density generated on the surface (aforementioned transthoracic current) and corresponding current density in the heart (transmucardial current) which needs to be above certain threshold, sufficient for stimulation of myocytes that are inexcitable.

In this preliminary work we propose the simplified model in which the uterus and stomach are modelled as a single area with larger conductivity. In order to account for frequency dependent properties of biological tissues we decompose the biphasic pulse into frequency component and perform frequency-domain analysis resulting in corresponding current harmonics.

We then calculate the amplitude of the current density harmonics in the lower abdomen and analyze these values with respect to position of electrodes and/or energy delivered by defibrillator.

Mathematical Model

In order to describe the mathematical model of the defibrillation we first describe the electric pulse that is applied to the patient's torso. Commonly used defibrillators commonly apply rectilinear biphasic pulse which consists of constant current pulse followed by truncated exponential decay pulse.

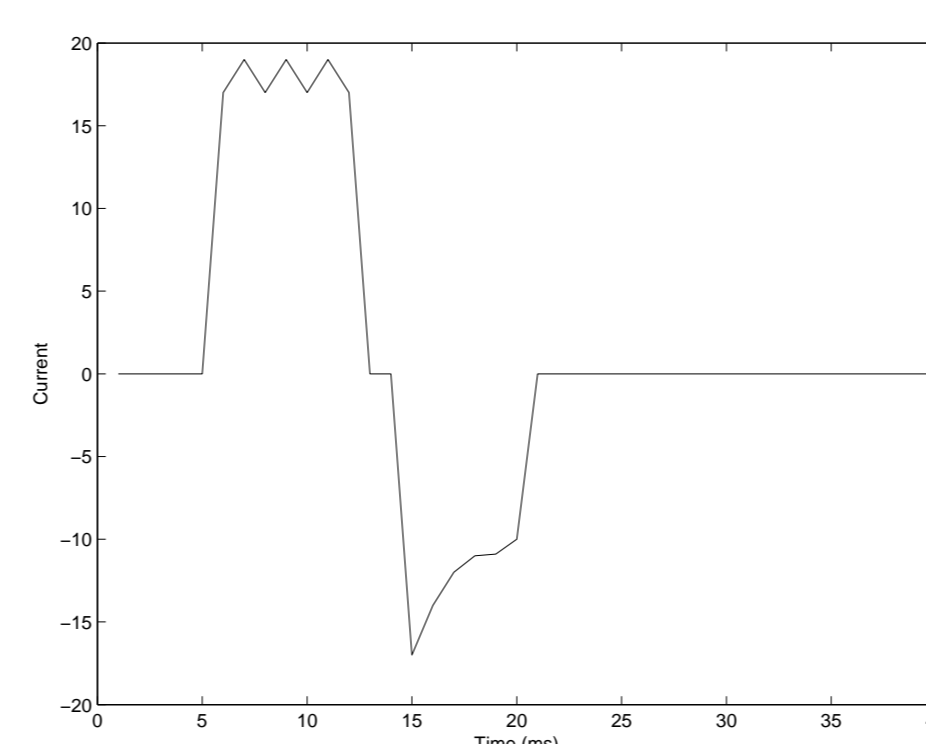

FIGURE 1: Time waveform of rectilinear pulse

We approximate tissues of the abdominal compartment (liver, gut, spleen, uterus) using a homogeneous equivalent tissue with slightly larger conductivity. For illustrational purposes in Figures 2 and 3 we illustrate frequency dependence of lung conductivity and permittivity.

Similarly Figures 4 and 5 show same values for human skin. These values were selected from reported estimates of tissue properties.

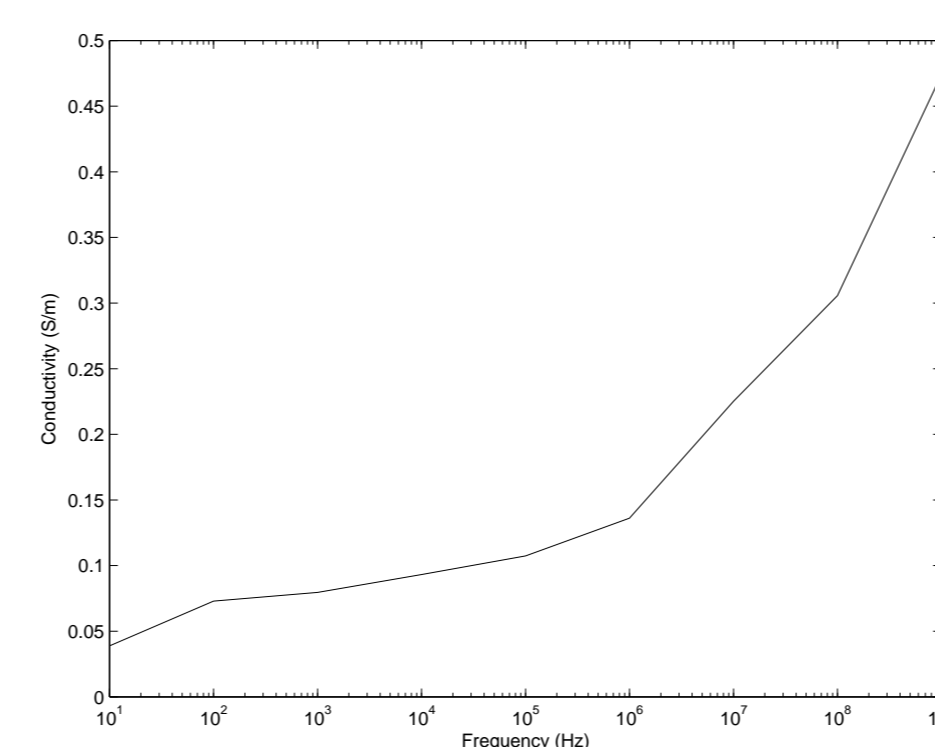

FIGURE 2: Average conductivity of lungs

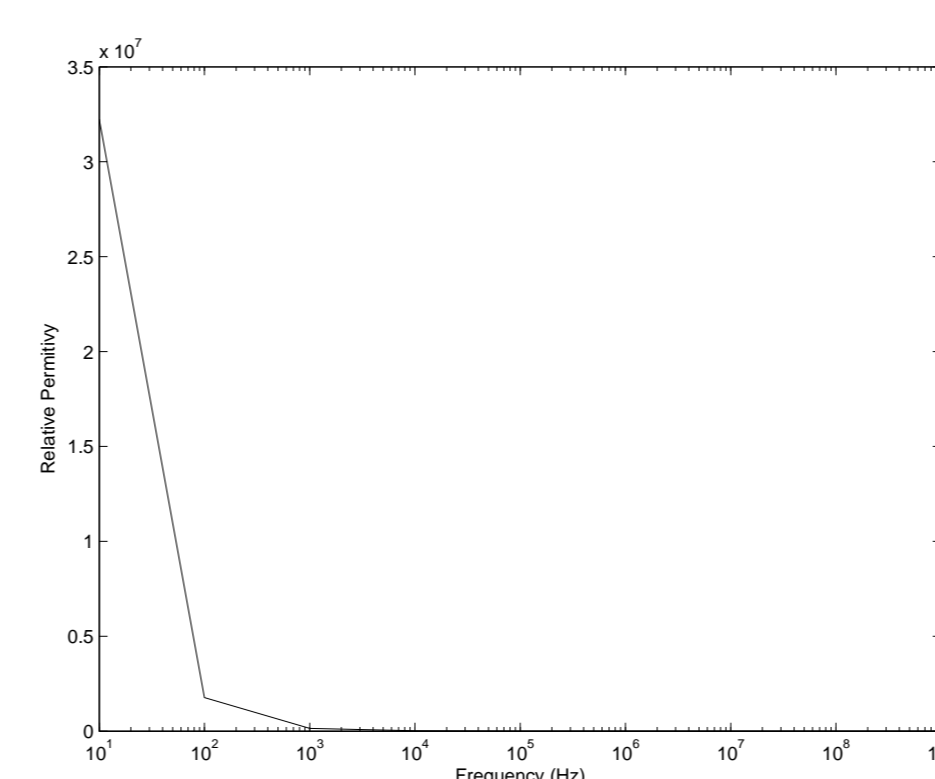

FIGURE 3: Average permittivity of lungs

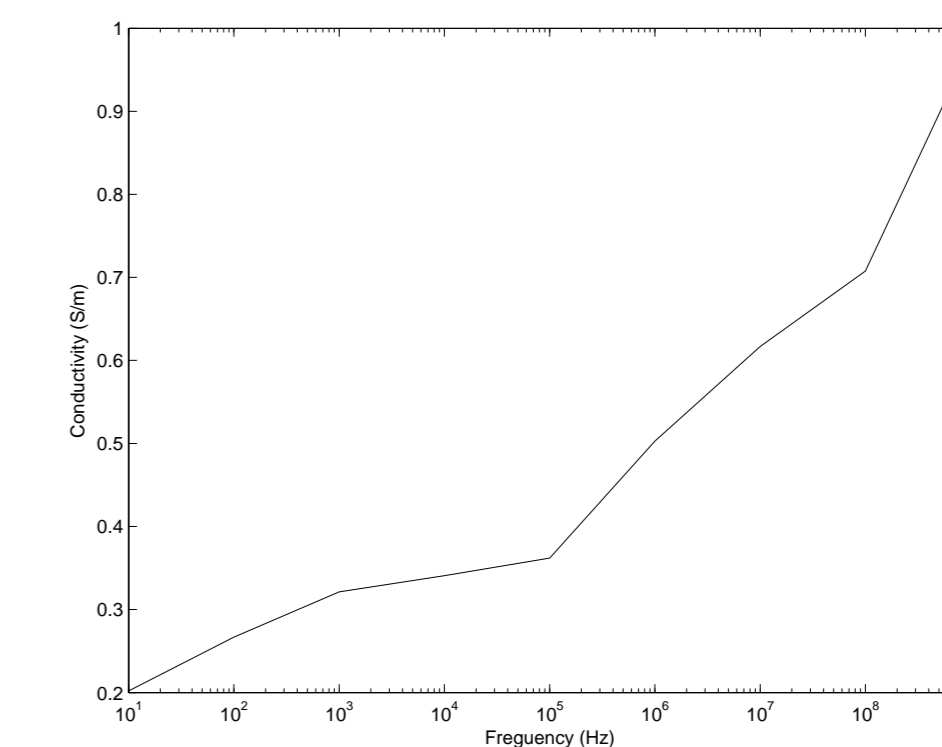

FIGURE 4: Average conductivity of muscle.

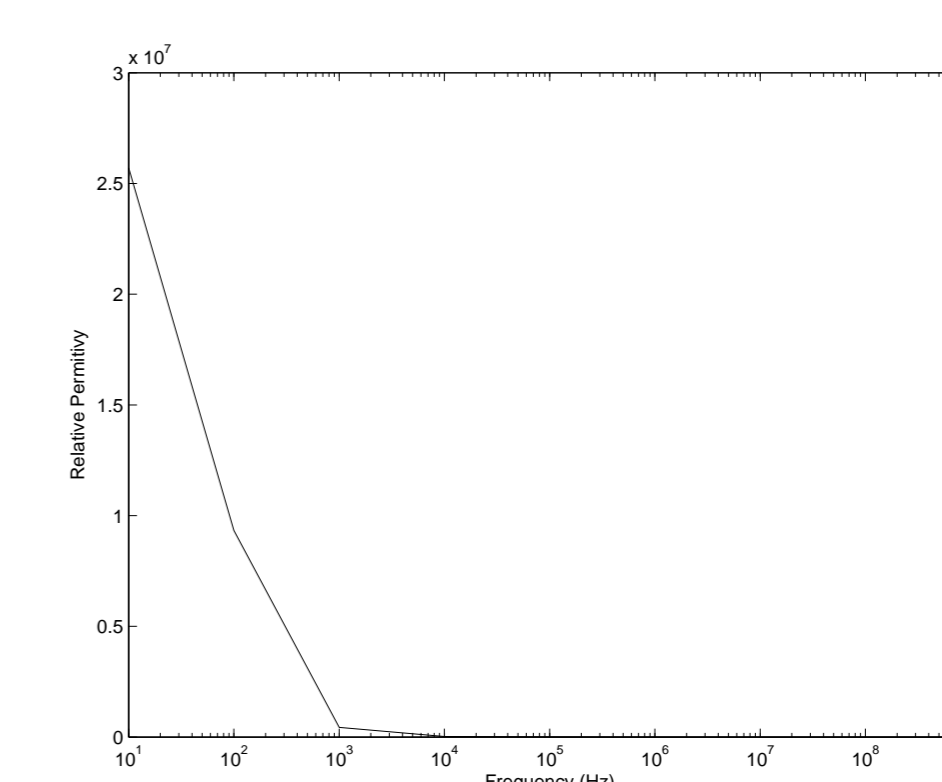

FIGURE 5: Average permittivity of muscle.



FIGURE 6: Model Geometry

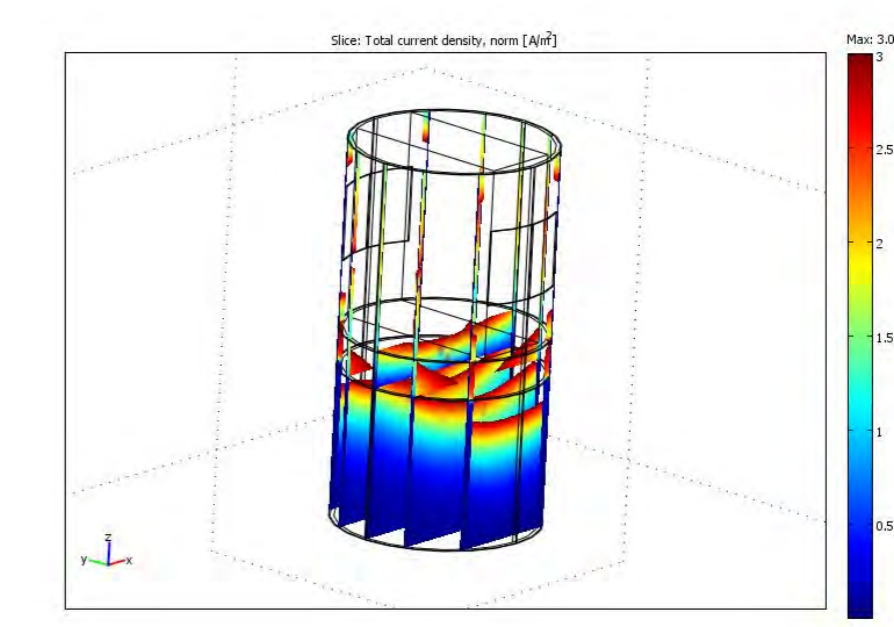

FIGURE 7: Current density at 1KHz

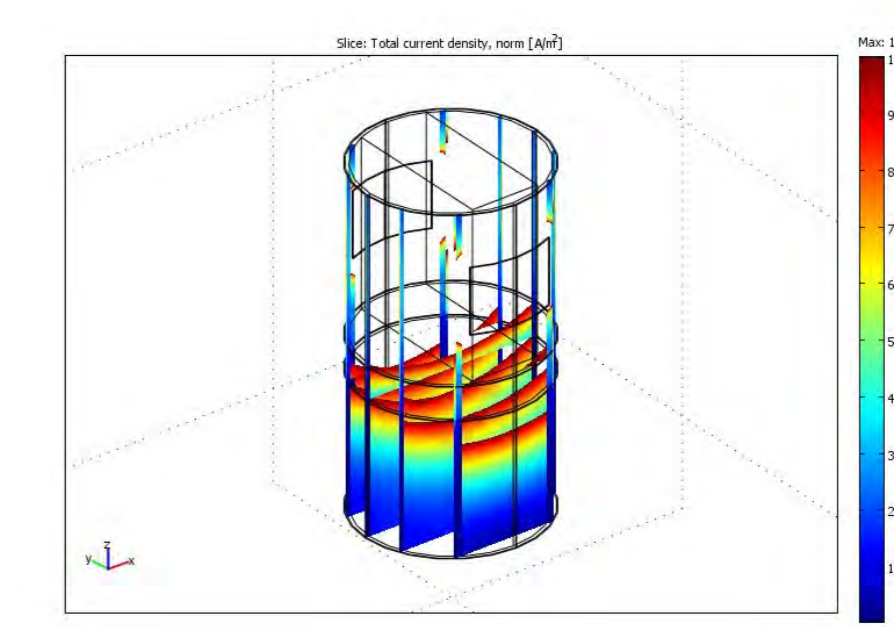

FIGURE 8: Current density at 1MHz.